



TO-V7402-7/9

Features

- Available in 28 finishes including 13 PVD finishes
- All brass construction
- 1.2 gpm (4.5 L/min) max flow rate
- Rough valve (VL-R) sold separately

Codes/Standards Applicable

Product meets or exceeds the following:

- ASME A112.18.1/CSA B125.1
- NSF/ANSI 61 & NSF/ANSI 372
- CEC / DOE
- EPA WaterSense High Efficiency Lavatory
- Commonwealth of MA
- ADA compliant

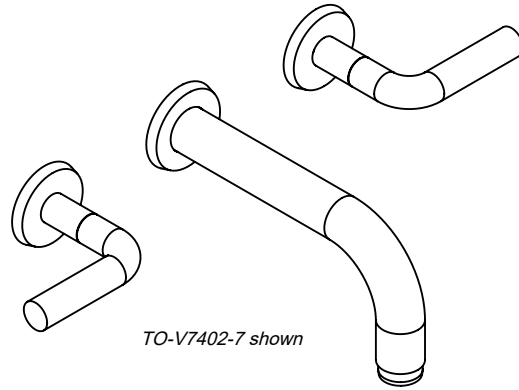

TO-V7402-7 shown

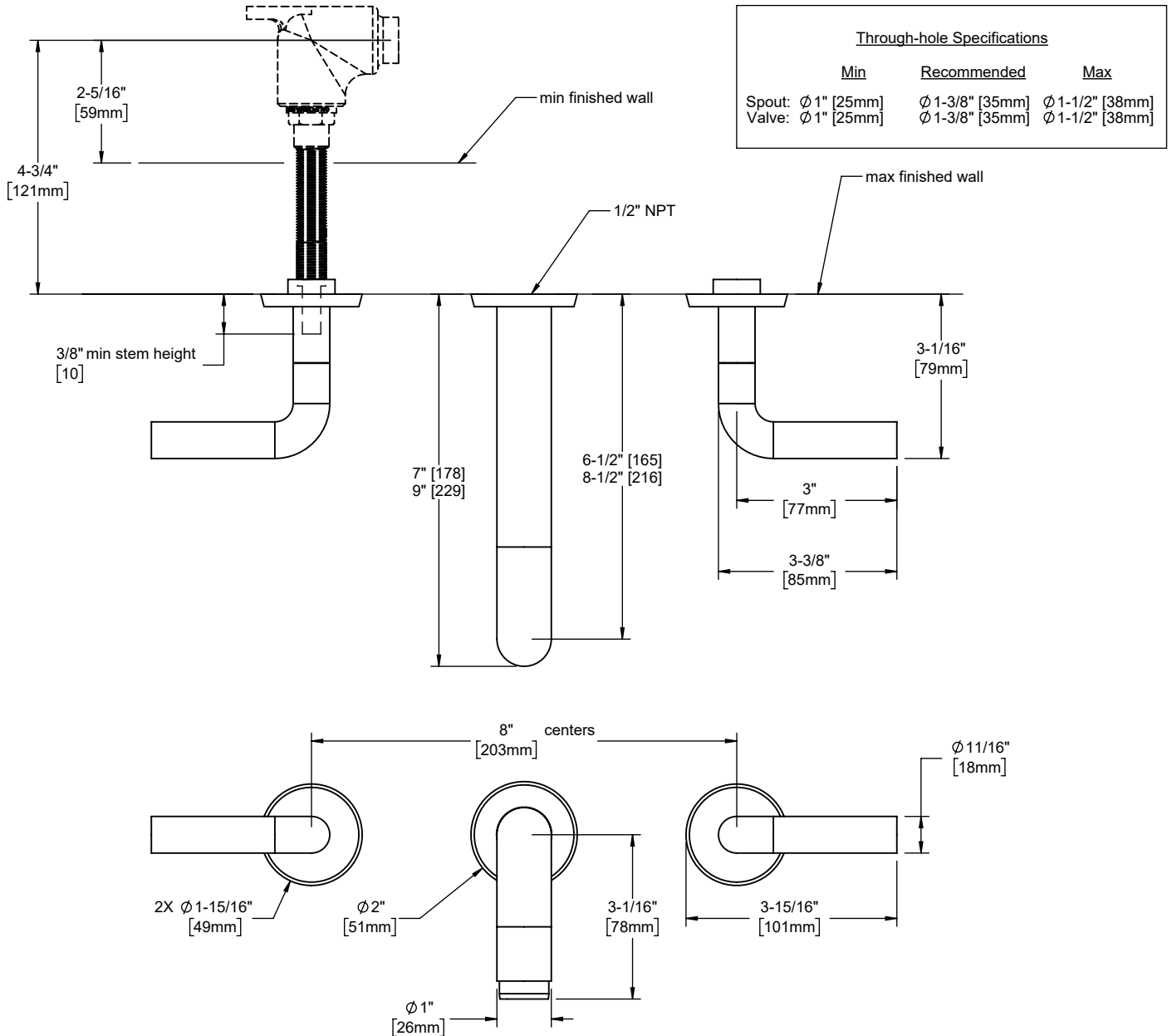



714.891.7797 Phone
714.891.2478 Fax
800.822.8855 Toll Free
californiafaucets.com

California Faucets®

VESSEL LAVATORY

CF-VL-R

INSTALLATION INSTRUCTIONS

California Faucets reserves the right to make modification and specification changes at any time. Please visit www.calfaucets.com for most current technical data.

Front View

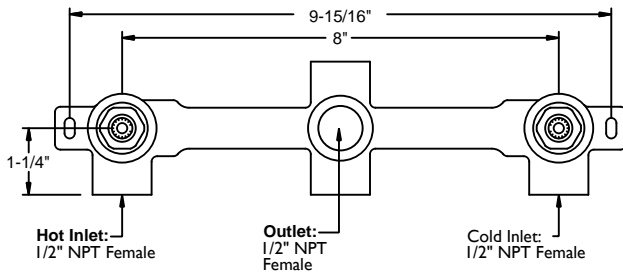

Side View

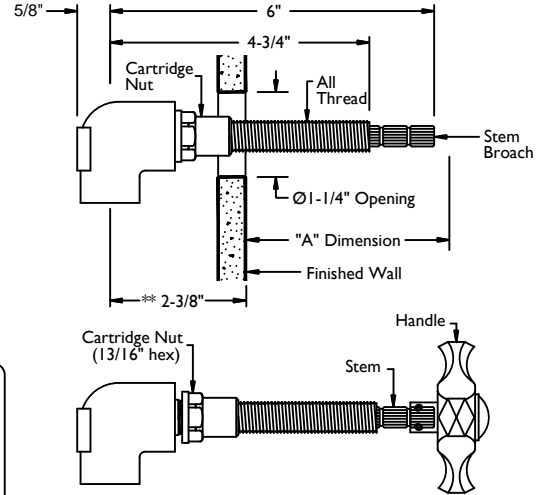

"A" DIMENSION

"A" Dimension is from finished wall to tip of stem broach

Handle Series #	"A"
33	2-3/8"
34	2-3/8"
35	2-3/8"
36	2-3/8"
38	2-5/8"
42	2-5/8"
45	2-1/8"
46	2-1/2"
47	2-1/2"
48	2-5/16"
50	2-1/4"
51	2-1/2"
55	2-5/8"
57	2"
60	2-1/4"
61	2-1/4"
62	1-7/16"
63	3"
64	2-5/8"
65	2-1/8"
66	2-1/8"
67	2-1/4"
68	2-3/8"
69	2-3/8"
70	1-3/8"
**71	1"
**72	1"
**73	1"

NOTE: In some cases, it may be necessary to re-align cartridge Stem to achieve desired handle alignment. To align stem, slightly loosen in a CCW direction the Cartridge Nut. Place Handle on Stem and **TIGHTEN** in a CW direction until desired alignment of handle is achieved. Retighten Cartridge Nut to factory torque setting of 14 ft-lbs. (Cartridge Nut size is 13/16" hex)

WARNING: Cartridge Nut **MUST** be properly torqued to prevent possible failure and/or water damage.

****NOTE:** For Series #71, 72 & 73 valve rough must be set back a minimum of 2-3/8" from finished wall surface to center of inlets.

NOTE: When fitting handle it may be necessary to shorten broach stem and/or all thread to eliminate gap between handle & escutcheon.

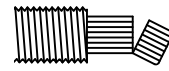

VS-47-7 & -9

For Series:
#46, 47, 51, 60 & 63

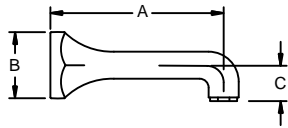

(Connecting nipple not supplied)

VS-47-7:	A=5-3/4"	B=2-3/4"	C=1-7/8"
VS-47-9:	A=8-1/2"	B=2-1/4"	C=1-5/16"

VS-62-7, -V7, -9 & -V9

For Series:
V6202-7/-V7
V6202-9/-V9

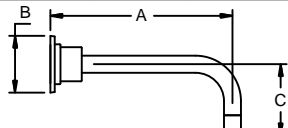

(Connecting nipple not supplied)

VS-62-7:	A=8"	B=2-1/2"	C=3-1/8"
VS-62-9:	A=10"	B=2-1/2"	C=3-1/8"

VS-65-7 & -9

For Series:
#45, 48, 65, 66 & V6202-27/-29

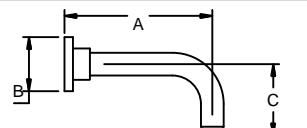

(Connecting nipple not supplied)

VS-65-7:	A=6-1/2"	B=2-3/8"	C=3-1/8"
VS-65-9:	A=8-1/2"	B=2-3/8"	C=3-1/8"

VS-64-7 & -9

For Series:
#38, 40, 42, 55, 57 & 64

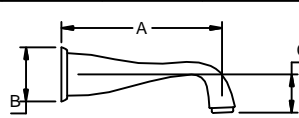

(Connecting nipple not supplied)

VS-64-7:	A=7-3/16"	B=2-3/8"	C=1-5/16"
VS-64-9:	A=8-3/8"	B=2-3/8"	C=1-5/16"

VS-67-7 & -9

For Series:
#33, 34, 35, 36, 51 & 67

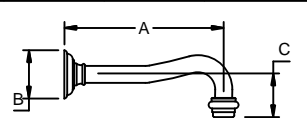

(Connecting nipple not supplied)

VS-67-7:	A=6-7/8"	B=2-1/8"	C=2"
VS-67-9:	A=10"	B=2-1/8"	C=2"

VS-68-9

For Series:
#50, 68 & 69

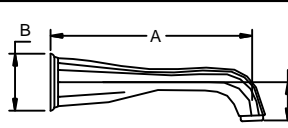

(Connecting nipple not supplied)

VS-68-9:	A=8-3/4"	B=2-3/8"	C=1-5/8"
----------	----------	----------	----------

VS-71**

For Series:
#71

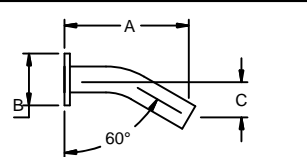

(Connecting nipple not supplied)

VS-71:	A=5"	B=2"	C=1-3/8"
--------	------	------	----------

VS-72-6 & -9**

For Series:
#72

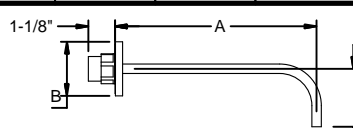

(Connecting nipple not supplied)

VS-72-7:	A=6-5/16"	B=2-1/4"	C=2-7/16"
VS-72-9:	A=8-5/16"	B=2-1/4"	C=2-7/16"

VS-73-6 & -9**

For Series:
#73

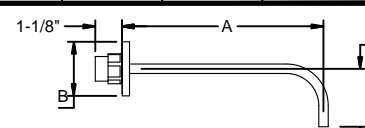

(Connecting nipple not supplied)

VS-73-7:	A=6-5/16"	B=2-1/4"	C=2-7/16"
VS-73-9:	A=8-5/16"	B=2-1/4"	C=2-7/16"

IMPORTANT CLEANING NOTICE Please refer to *Finish Care Instructions* for complete cleaning information. Wipe frequently with a soft, damp cloth. **Never use acids, harsh abrasives or detergents.**