

TRADITIONAL SINGLE PORT AIR GAP

4020

- MAX COUNTER THICKNESS 1-1/4"
- INSTALL HOLE SIZE ADAPTABLE UP TO 1-3/8"

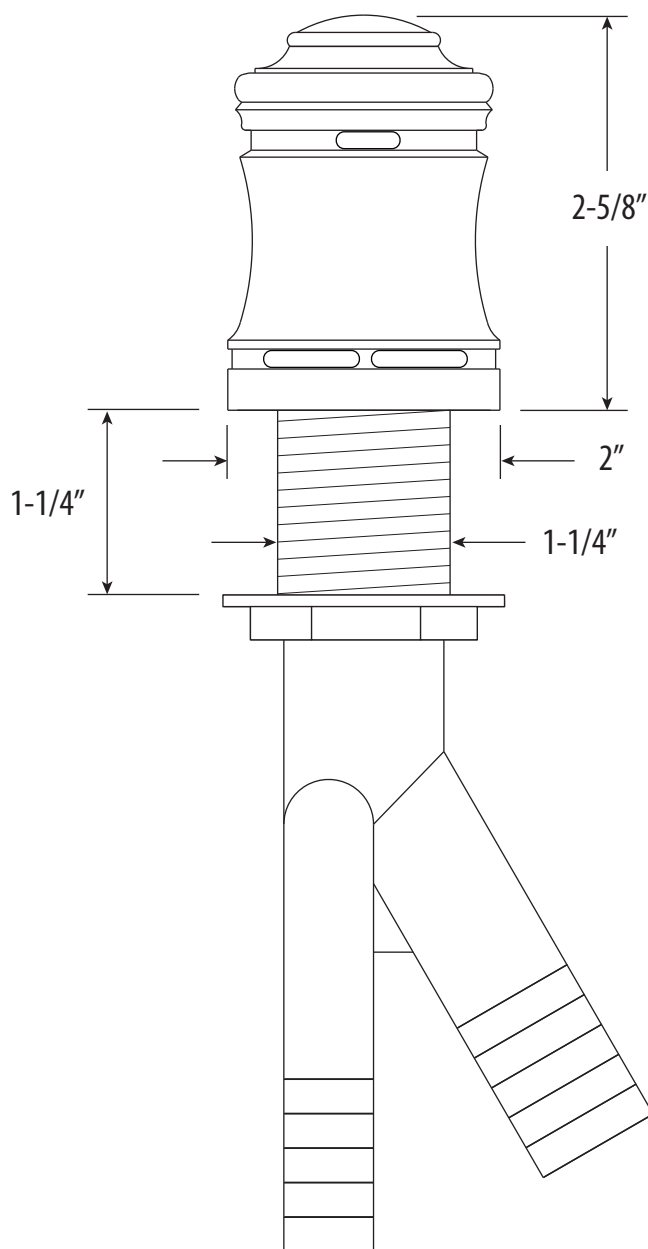

DIMENSIONS MAY VARY AND ARE SUBJECT TO CHANGE. NO RESPONSIBILITY IS ASSUMED FOR USE OF SUPERCEDED OR VOIDED DATA



BEFORE YOU BEGIN YOUR INSTALLATION:



Turn off water supply.

REQUIRED TOOLS:



1. Phillips Screwdriver

PARTS INCLUDED:

Optional Button Caps -
Logo and Finish
(TRADITIONAL MODELS ONLY)

- A. SINGLE PORT AIR GAP
- B. DRAINAGE HOSE*
- C. INTAKE HOSE*
- D. DISHWASHER

*NOT INCLUDED

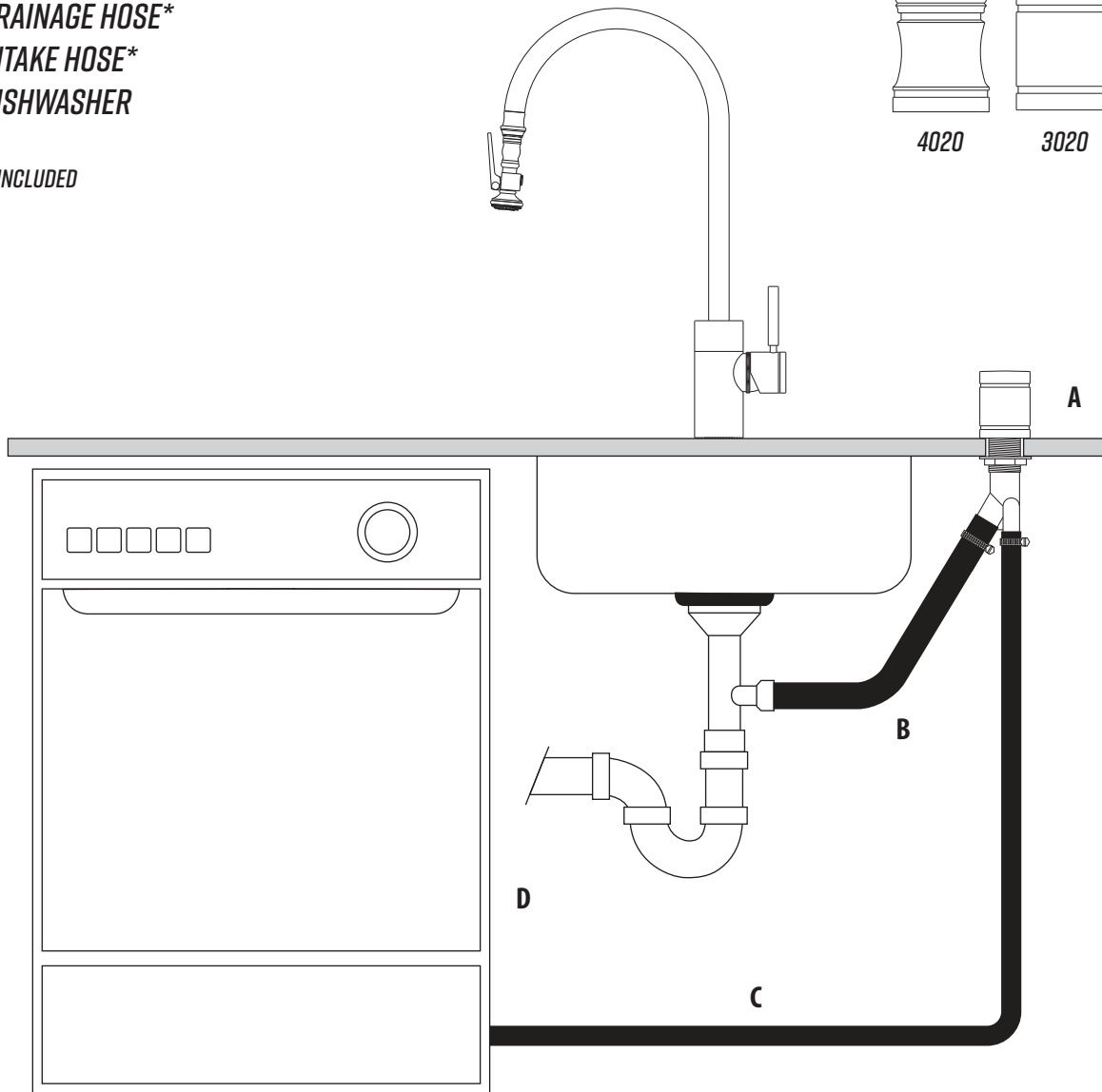
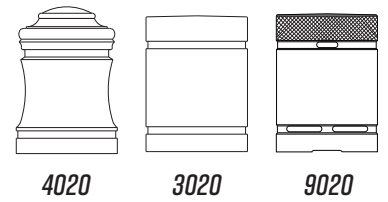

SINGLE PORT AIR GAP INSTALLATION

MODELS # 3020, 4020, 9020

